

---

# SPRINT & SPRINT XP

## INSTALLATION AND OPERATING INSTRUCTIONS

---



**Copyright © 2002-2004, PRI Ltd. 9600-3006-2 Issue C**

*Information contained within this document is subject to change without notice and does not represent a commitment on the part of PRI Ltd or its agents. E&OE.*

### **IMPORTANT SAFETY INFORMATION**

Care must be exercised during the installation of Sprint and Sprint XP meters and associated equipment due to the presence of mains voltages.

Local best practice and regulatory stipulations must always be observed.

Installation should only be performed by suitably trained personnel. Various points under the terminal cover operate at hazardous voltages.

Each Sprint or Sprint XP must be protected by fuses or voltage isolating links in each voltage circuit (see Section B). There are no user-serviceable or installer-serviceable parts inside. Removing the cover with power applied exposes potentially hazardous voltages.

Under no circumstances should the conductors be exposed when the circuit to the consumer is live.

After installation access to the connectors and conductors must be prevented by fitting the covers supplied, ensuring that they are secured in position with the screws provided and sealed in accordance with local practice

Suitable cabling must be used if mains voltages are to be connected to the input or output terminals. Double insulated cabling of at least 16 mm<sup>2</sup> must be used.

#### **CE MARKING DECLARATION OF CONFORMITY**

Sprint and Sprint XP meet standard BS EN 61036:1997, and therefore conform to EU Directive 89/336/EEC 'EMC Directive' as amended by 92/31/EEC and 93/68/EEC.

## SECTION A: INSTALLATION

### How to fix the meter in position

Sprint meters are designed for vertical mounting, and can be fitted to meter panels, boards, enclosures or walls. Suitable screws must be selected to ensure a good fixture. Screws of up to M4 or 4BA size can be used. Sprint and Sprint XP meters use the same three-point fixing arrangement. The top screw is located on the meter's centre-line and fits into a 'key-hole' locator on the rear-plate of the meter. This screw supports the meter in position on the surface to which it is to be attached. Two other screws are fitted through the terminal block of the meter and are used to secure it against the mounting surface.

The fixing centres are as shown on this view of the rear panel of a Sprint XP:

1. Mark out the position of the meter on the mounting surface, drill a hole and fit the top fixing screw.
2. Fit the Sprint over the top fixing screw taking care to align it correctly within the 'key-hole' locator.
3. With the terminal cover removed, mark out the positions of the lower fixing screws.
4. Remove the meter, drill holes for the lower fixing screws.
5. Fit the meter over the top fixing screw again.
6. Fit the lower fixing screws

**Fig. 1 Fixing Centres for Sprint and Sprint XP**

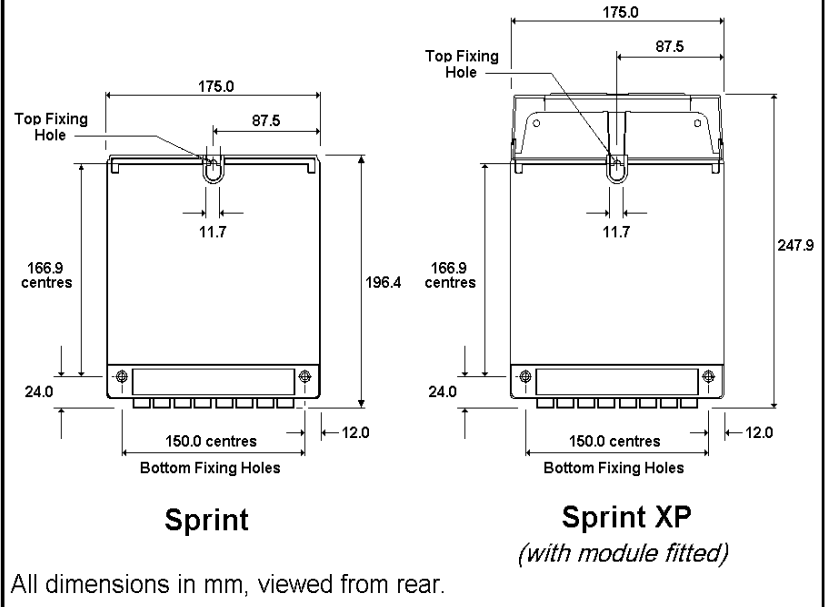

**Note:** Sufficient space must be provided on all sides of the meter when the fixing centres are marked out. For Sprint XPs sufficient headroom must be allowed for modules to be removed or replaced.

## SECTION B: ELECTRICAL CONNECTIONS AND WIRING CONFIGURATIONS

Sprint and Sprint XP are pattern approved by OFGEM for use as billing meters on 1, 2 or 3 phase connections.

Standard hardware configurations exist for single-phase or three-phase use; blanking plugs are fitted in unused conductor bores.

**Fig. 2 230 V 3 phase 4 wire whole current meter connections**

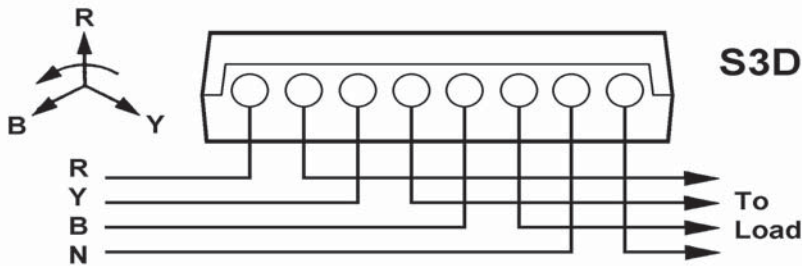

**Fig. 3 230 V 1 phase 2 wire whole current meter connections**

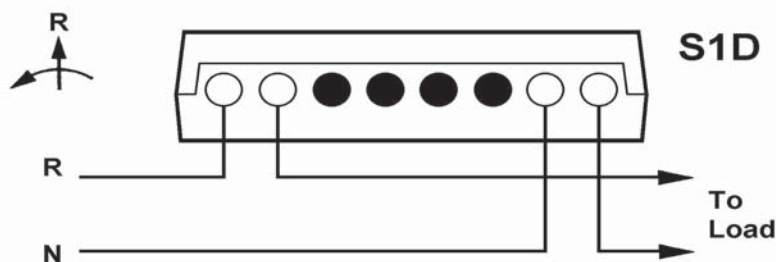

Note: For single-phase installations any of the phases can be connected; it does not have to be the red phase.

## SECTION C: FITTING CONDUCTORS

Local best practice must be observed when selecting conductor size and type.

All Sprint and Sprint XP models can accept cabling up to 35 mm<sup>2</sup> conductor area and with outside diameter up to 10 mm. Cables larger than 10 mm outside diameter require the outer sheath to be cut back before the cable is inserted into the conductor bore.

Sprint XP meters are also available with a larger conductor bore which can accept cables of up to 50 mm<sup>2</sup> conductor area and with outside diameter up to 14 mm.

The cables must be cut and trimmed carefully. The insulation must be cut back and removed 'squarely' to ensure that the inner insulation is not exposed on the portion of the cable outside the conductor bore.

The following are suggested lengths for the exposed copper and inner insulation of the cabling.

**Table 1: Cutting Details for Typical Cable Sizes**

Cable Size	Standard Conductor Bore	Large Conductor Bore
25mm <sup>2</sup> (11mm outside diameter)	28mm copper 8mm inner sheath	30mm copper No exposed inner sheath
35mm <sup>2</sup> (12mm outside diameter)	32mm copper 5mm inner sheath	32mm copper No exposed inner sheath
50mm <sup>2</sup> (15mm outside diameter)	Not Applicable	35mm copper 5mm inner sheath

The process for fitting the conductors is as follows:

1. Cut and trim the cables (see Table 1 and Fig. 4).
2. Loosen the conductor screws fully
3. Insert the cable fully into the conductor bore, ensuring that no inner insulation is exposed external to the meter (see Fig. 5).
4. Tighten the conductor screws

**WARNING: The maximum permissible torque setting for the conductor screws is 2.5 Nm**

5. Check that the independent potential (IP) links are in the closed position
6. Replace the terminal cover

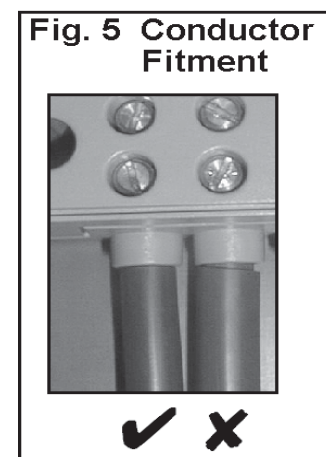
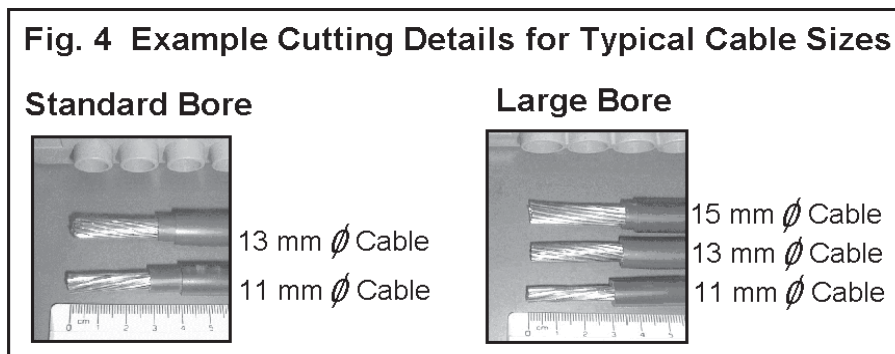

## SECTION D: INDEPENDENT POTENTIAL LINKS

Sprint and Sprint XP meters are fitted with Independent Potential (IP) links for testing purposes. The IP links are sprung metal contacts that enable a separate (independent) voltage to be applied to the internal circuitry. The links must be in the closed position for normal operation.

The terminal cover has protusions on its inside face which help to close the links, and which ensure they remain closed during the service life of the meter.

If any links are found in the open position during installation it is recommended that they be closed manually before the terminal cover is fitted and before power is applied to the meter.

**Warning: The IP links are at mains potential when the meter is powered up.**

**Fig. 6 Closing the Independent Potential Links**

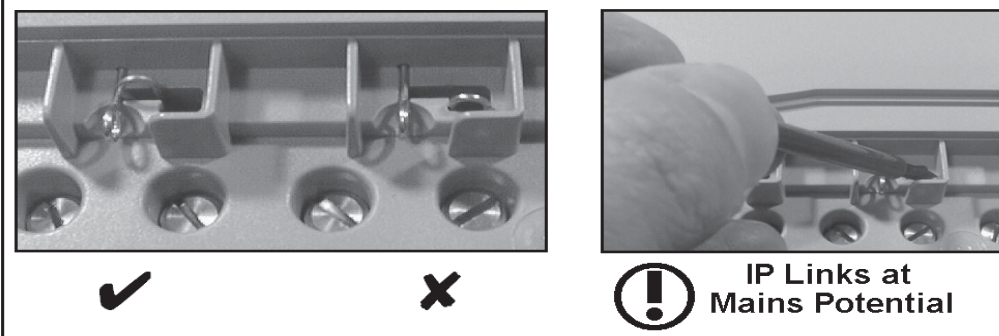

## SECTION E: INPUTS AND OUTPUTS

Sprint and Sprint XP meters have a pulsed output connection available under the terminal cover. This is controlled by a combination of the CLEM operating program and tariff configuration file loaded into the meter. The CLEM and tariff are indicated on the LCD at the end of 'Page 3', see section J for details.

The standard configurations output 10 pulses per kWh for active (consumed) energy.

The output terminals can accept cables up to 2.5 mm<sup>2</sup>, and are rated for use at mains potential or with low voltage dc equipment. Up to 100 mA can be switched by the pulsed output. For inductive loads an external snubber circuit should be fitted.

Sprint and Sprint XP meters are fitted with a state-sensing pulsed input for synchronisation with an external time reference. This input is disabled for all standard programming options.

**Warning: Double-insulated cables should be used if mains voltages are connected to the pulsed output terminals.**

**Fig. 7 Pulsed Output Circuit**

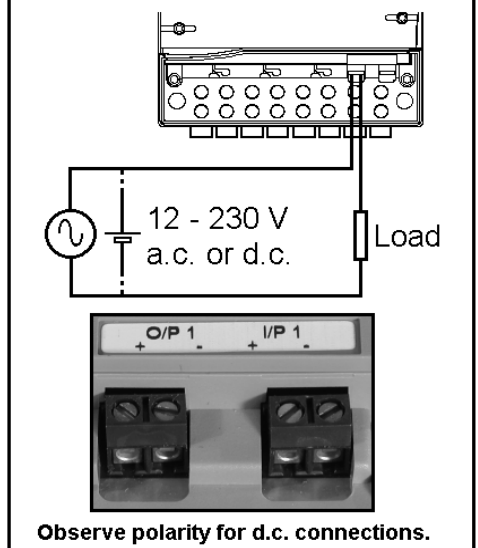

## SECTION F: XP MODULES

Sprint XP meters can be supplied fitted with an XP module to provide additional functionality including pulsed outputs or multi-utility inputs. Two different XP modules are available; CoP5 and CoP5 with modem. Both XP modules fulfill the hardware requirements of UK Code of Practice 5 for consumers with a demand not exceeding 1 MW.

**Note: XP modules can only be fitted to Sprint XP meters. Basic Sprint meters are not fitted with a hardware interface for XP modules and cannot be upgraded. Although XP modules are normally fitted at manufacture it is possible to fit modules in the field, or to move modules between Sprint XP meters.**

CoP5 XP modules are fitted with three pulsed outputs in addition to the single pulsed output provided on the meter under the main terminal cover. The output connections are accessed under the 'ear' connection at the top left hand end of the module, together with the modem socket (when fitted).

The pulsed outputs on the module are similar to the output under the main terminal cover. The output terminals can accept cables up to 2.5 mm<sup>2</sup>, but are rated for use only with low voltage dc equipment. Up to 100 mA can be switched by the pulsed output. For inductive loads an external snubber circuit should be fitted.

For Sprint XP meters fitted with CoP5 modules (with or without modem) the pulsed outputs are configured as follow:

- Output 1 (under main terminal cover): 10 pulses per kWh
- Output 2 (on module): 10 pulses per kVAh
- Output 3 (on module): 10 pulses per kvarh
- Output 4 (on module): End of DIP signal. A 10 second pulse at the end of each half hour.

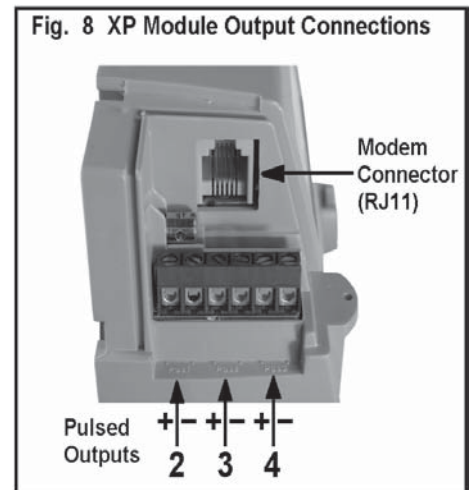

The modem (where fitted) is a BABT approved model (Certificate No. Z8 00 1242367 001) for connection to PSTN lines at 1200 bd.

## How to Fit XP Modules

Sprint XP modules are designed for 'hot swapping' and can be fitted or replaced when the meter is powered up. The process is as follows:

1. Remove the module terminal covers ('ears') and loosen the securing screws on the module.
2. Hook the left-hand end of the interface circuit board into position on top of the Sprint XP
3. Push the right-hand end of the interface circuit board firmly into position, ensuring that the three-pin header is correctly seated
4. Re-connect the module securing screws, and fit the 'ears'.
5. Initialise the module by pressing the right-hand button and holding it in for approximately five seconds until the meter display indicates 'Code 5'.

---

## SECTION G: COMMUNICATIONS

---

Sprint and Sprint XP meters are equipped with two communications ports mounted on the front cover. Both ports use PRI's proprietary PACT protocol. This can be used to extract meter readings using PRI software, or can be used to interrogate instantaneous parameters such as voltage, current, power etc.

The PACT port is a slot mounted on the front panel of the meter to which PACT probes can be fitted for local or remote communications.

The '1107' port is located to the right of the PACT port and takes the form of a standard magnetic annulus to which a local read probe can be attached.

Sprint XP meters fitted with CoP5 modules store half-hourly load profile data for active, apparent and reactive parameters. The module can hold data for the 'today' and the 50 preceding days.

Load survey can be read out using PRI's Principal or EASEii software, and the format is also supported by a number of third-party data collectors.

Load survey, meter readings and instantaneous data can also be read out over PSTN connection on Sprint XP meters equipped a 'CoP5 with modem' module.

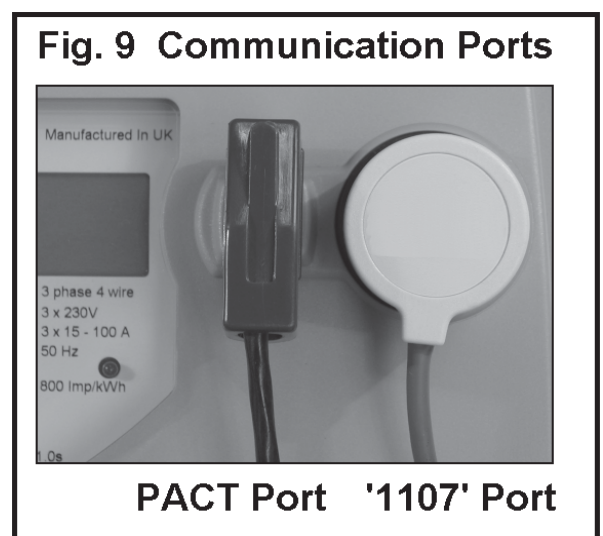

All communications ports, including the modem (where fitted), are configured at manufacture for operation at 1200 bd.

**SECTION H: DISPLAY OPERATION**

Sprint and Sprint XP meters are equipped with an LCD window for displaying metering and status information.

The display is operated using the push buttons mounted on the front panel.

The right-hand button is used to actuate the display; each press advances the display by one position in the 'display sequence' programmed at manufacture. The display sequence is split into a number of pages which can be selected using the left-hand button (Sprint XP) or by pressing and holding in the right-hand button for five seconds (Sprint).

The exact configuration of the display is determined by the combination of CLEM program and tariff file loaded into the meter at manufacture. Note that 'time-of-use' tariff rate registers, such as 'day' and 'night', are only displayed if implemented in the tariff loaded into the meter at manufacture. The default tariffs for each programming option do not include time-of-use tariff files, therefore the only rate register normally displayed is 'rate 0', unless a particular tariff arrangement was specified at time of ordering.

Note that the 'Heathrow' specification includes two time-of-use registers; 'Rate 1' from midnight to 7 am and 'Rate 2' from 7 am to midnight.

This document covers the 'standard' configurations available from PRI, for 'Sprint', 'CoP5', and 'Heathrow' options.

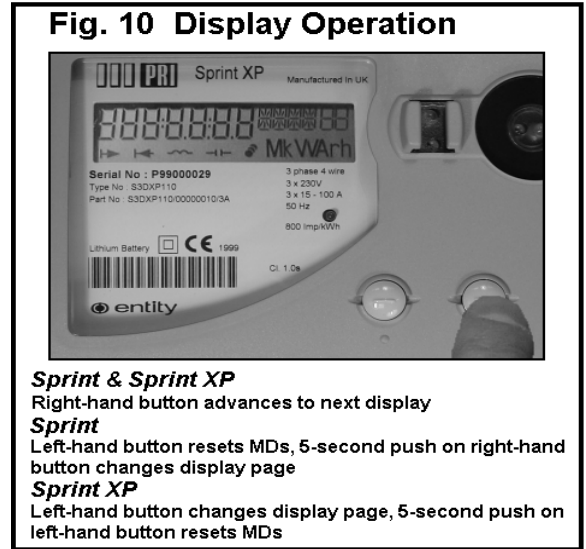

**SECTION I: DISPLAY OPTIONS IN TARIFF**

**Table2. Display Availability for Typical Sprint and Sprint XP Programming Options**

Display Number	Sprint	Sprint XP Profile Sprint XP CoP5 (and CoP5 + modem)	Heathrow Spec
	TARF2000/TRF2E300/310	COP52010/PROF3010	LHRP0001/LHRPE310
<b>Page 1</b>			
1	Active Rate	Active Rate	Active Rate
2	Current Page	Test Pattern	Test Pattern
3	Test Pattern	Current Page	Total kWh
4	Total kWh	Total kWh	Total kWh
5	Total kVAh	Total kVAh	Power Factor
6	Total kvarh	Total kvarh	MD kVA
7	MD kW	MD kW	Rate 1 (00:00 to 07:00h)
8	Billing MD kW	MD kVA	Rate 2 (07:00 to 24:00h)
9	Cumulative MD kW	Billing MD kW	MD reset count
10	MD reset count	Billing MD kVA	Time
11	Time	Cumulative MD kW	Date
12	Date	Cumulative MD kVA	Primary Current
13	Rate 1 etc.	MD reset count	Primary Voltage
14		Time	LED Scaling
15		Date	CLEM Name
16		Rate 1 etc.	Tariff Name
<b>Page 2</b>			
1	Current Page	Current Page	
2	Rising Demand kW	Rising Demand kW	
3	Rising Demand kVA	Rising Demand kVA	
4	Power Factor	Power Factor	
5	Phase Presence	Phase Presence	
6	Frequency	Frequency	
7	Red Line Current	Red Line Current	
8	Yellow Line Current	Yellow Line Current	
9	Blue Line Current	Blue Line Current	
10	Red Active Current	Red Active Current	
11	Yellow Active Current	Yellow Active Current	
12	Blue Active Current	Blue Active Current	
13	Red Reactive Current	Red Reactive Current	
14	Yellow Reactive Current	Yellow Reactive Current	
15	Blue Reactive Current	Blue Reactive Current	
16	Red Voltage	Red Voltage	
17	Yellow Voltage	Yellow Voltage	
18	Blue Voltage	Blue Voltage	
<b>Page 3</b>			
1	Current Page	Current Page	
2	Primary Current	Primary Current	
3	Primary Voltage	Primary Voltage	
4	Hi-Res. kWh	Test LED Value	
5	CLEM Name	Hi-Res. kWh	
6	Tariff Name	CLEM Name	
7		Tariff Name	
8		Module Status	

SECTION J: DISPLAY FORMATS

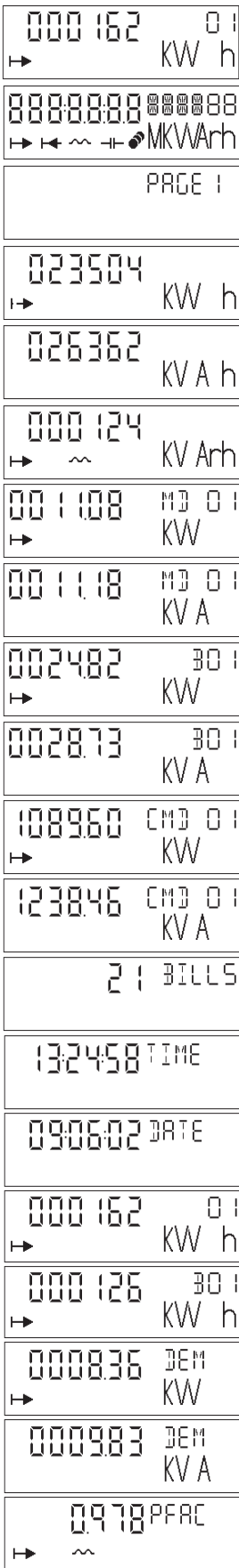

**Active Rate:** This display shows which tariff rate is active, together with the value accumulated in it.

**Test Pattern:** All segments illuminated.

**Page Identifier:** for Page 1, 2, 3 etc.

**Total kWh:** Shows total consumed active units since manufacture.

**Total kVAh:** Total apparent energy units since manufacture. Increments for imported or exported energy.

**Total kvarh:** Shows total reactive consumed (lagging) energy units since manufacture.

**MD for kW:** Shows kW maximum demand for current billing period. (Reset at the end of each month).

**MD for kVA:** Shows kVA maximum demand for current billing period.

**Billing MD for kW:** Shows kW maximum demand for previous billing period.

**Billing MD for kVA:** Shows kVA maximum demand for previous billing period.

**Cumulative MD for kW:** At the end of each month the value in the kW MD register is added to this register.

**Cumulative MD for kVA:** At the end of each month the value in the kVA MD register is added this register.

**MD Reset Count:** Shows the number of MD resets (monthly billing and presses of the MD reset button).

**Time:** In HH:MM:SS format, GMT only, no adjustment for summer time (BST).

**Date:** In DD:MM:YY format.

**Rate Register 1:** The units accumulated in tariff rate 01, 02 etc. For meters with more than one rate.

**Billing Rate 1:** Shows the units in accumulated in tariff rate 01, 02 etc 'frozen' at the last billing point.

**Rising Demand for kW:** Shows the kW demand for the current half-hour period. Reset every half-hour.

**Rising Demand for kVA:** Shows the kVA demand for the current half-hour period. Reset every half-hour.

**Power Factor:** Instantaneous average three-phase power factor. A 'minus' sign indicates 'leading'.

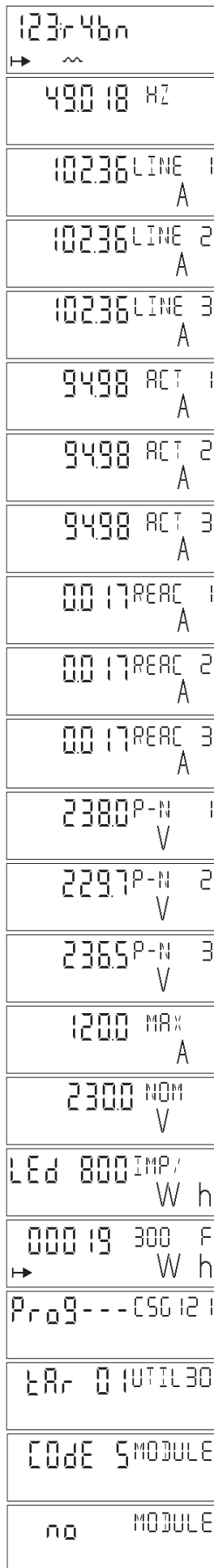

**Phase Presence:** '123' indicates correct rotation. 'rybn' shows all phases present.

**Supply Frequency:** Instantaneous mains frequency, updated each second.

**Phase 1 Line Current:** Apparent current for red phase, updated every second. Shows magnitude only.

**Phase 2 Line Current:** Apparent current for yellow phase, updated every second.

**Phase 3 Line Current:** Apparent current for blue phase, updated every second.

**Phase 1 Active Current:** In-phase current for red phase. A 'minus' sign indicates the current is reversed.

**Phase 2 Active Current:** In-phase current for yellow phase.

**Phase 3 Active Current:** In-phase current for blue phase.

**Phase 1 Reactive Current:** Out-of-phase current for red phase, updated every second. A 'minus' sign indicates 'leading'.

**Phase 2 Reactive Current:** Out-of-phase current for yellow phase.

**Phase 3 Reactive Current:** Out-of-phase current for blue phase.

**Phase 1 Voltage:** For 3-phase 4-wire meters the red phase to neutral voltage is shown, updated every second.

**Phase 2 Voltage:** Yellow phase to neutral voltage.

**Phase 3 Voltage:** Blue phase to neutral voltage. (3-phase 3-wire meters show phase to phase voltage).

**Current Rating:** The maximum current at which the meter maintains its accuracy rating.

**Voltage Rating:** The nominal phase to neutral voltage rating for the meter.

**Test LED Output Value:** This shows the 'units per increment' for the LED activity indicator, 800 flashes per kWh.

**High-Resolution Energy:** Shows fractional units to a greater resolution than the total unit displays.

**CLEM Program Name:** Shows the 'family', 'variant' and the 'version'.

**Tariff Configuration File:** Note the order in which the characters are displayed. The example is for 'UTIL3001

**Module Status:** Sprint XP Only. Indicating that a CoP5 module is fitted and is operating correctly.

**Module Status:** Sprint XP Only. Indicating that no module is fitted, or that a module is not fitted correctly.

*Note: There are minor differences between Sprint and Sprint XP display formats. For example Sprint shows 'CHAN 1, 2, 3' for total energy registers and 'RATE' for rate registers.*

## SECTION K: METER SCALING AND ACCURACY

Sprint and Sprint XP are direct-connected, 'whole current', meters, with a fixed scaling set at manufacture.

In traditional UK parlance such meters are often referred to as '40/100 Amp' meters, indicating the normal operating range for the accuracy classification.

Sprint and Sprint XP are OFGEM approved for a range of wiring configurations and operating ranges as indicated below:

- 3 phase 4 wire
- 1 phase 2 wire
- 2 phase 3 wire
- 2 phases of 3 phase 4 wire

Accuracy Class 1 for active measurements, 20-40/80/100 A.

Meter scaling also affects the value of output pulses related to energy consumption and the value of 'units' communicated when the meter is read electronically. For a Sprint or Sprint XP the following apply:

- Meter units on display (meter factor or 'last dial value') x 1kWh
- LED activity indicator emits 800 flashes per kWh
- Default value (pulse weight) for energy pulsed outputs = 10 per kWh (or kVAh, kvarh as appropriate)

The rated power for a Sprint or Sprint XP is calculated in the following way:

For 3p 4w meter the rated power is (3 x (primary phase to neutral voltage x primary current))

*For a 230 V, 100 A S3D the rated power is 3 x 230 x 100 = 69,000 W = 69 kW*

## SECTION L: PART NUMBER SYSTEM AND SPECIFICATIONS

<b>Dimensions</b>	
Sprint	W 176 x H 250 x D 67 mm
Sprint XP	W 176 x H 303 x D 67 mm
<b>Weight</b>	
Sprint	1.0 kg
Sprint XP with module	1.2 kg
<b>Enclosure</b>	ABS / Polycarbonate
<b>Protection</b>	IP 51 UL 94 V0
<b>Burden per Phase</b>	(for 3-phase meter)
Current Circuits	< 0.6 VA at 40 A, UPF
Voltage Circuits	< 1.6 VA each, for 3-phase < 2.5 VA for 1 phase

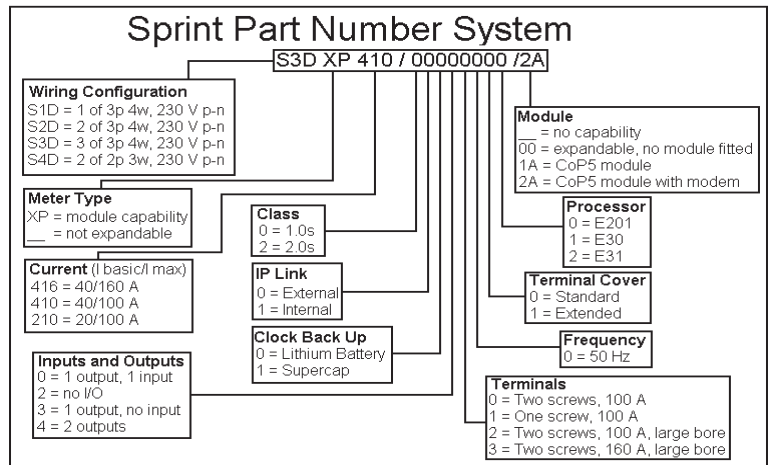

**Table 4. Load Survey and Pulsed Output Availability for Typical Programming Options**

Tariff	TRF2	PROFILE	COP5	LHRP
		Load Survey		
Number of Days	None	129	52 days	None
Parameter 1		kW	kW	
Parameter 2			kVA	
Parameter 3			kvar	
		Output Pulses		
Output 1 (under terminal cover)	kWh	kWh	kWh	kWh
Output 2 (on module)		kVAh	kVAh	
Output 3 (on module)		kvarh	kvarh	
Output 4 (on module)		MD Synch	MD Synch	